

RBS

/PR-V /TM-V

Operating and maintenance instructions for blowers.

*Instruction for
Transport | Installation | Operation | Maintenance*

Type

S/N

Manufacturing year

2016

HeliPower[®]

GENERAL INFORMATION

This manual is integral part of the machine follow strictly the instructions given in this Manual prior to positioning and operating the blower.

For a quick and rational reading of this manual observe the following statements and definitions :



Warning : Signals the risk of serious injures to people and/or serious danger to blower



Note : Signals important technical information for the operation of the blower

*Follow strictly the **SAFETY INFORMATIONS** at page 3 prior any operation on blower*

Qualified personnel

It means these persons who, on account of their training, experience and instruction and their knowledge of relevant standards, specifications, accident prevention rules and operating conditions, have been authorized by those responsible for the safety of the plant to carry out the necessary work on the blower and who can recognize and avoid any possible dangers.

Acknowledge of first aid is also required as is information about local rescue facilities.

The blower is a rotary lobe compressor suitable only for industrial use as described in this Manual. Any other use is to be considered improper and is therefore forbidden.

*The blower must be installed in a safe area, accessible only by **qualified personnel**.*



Warning : Non-qualified personnel are not permitted to work on or near the blower

The personnel in charge must be well acquainted with this Manual, and then conserve carefully the Manual in a known site in order that it be available for future consultations.

*The maintenance operations are to be carried out by **qualified personnel** following the instructions given in this Manual and using only original spare parts.*

SAFETY INFORMATION

The CUSTOMER must verify that the operating environment, the power circuits, the control circuits and the other controls or equipments related to the function of the blower satisfy the essential safety requirements of the European Machinery Directive 2006/42/CE and/or of the corresponding legislation of the country where the blower is used.

The CUSTOMER must also ensure that the valid legislation on electric safety (Low-Voltage Directive) and Electromagnetic Compatibility of equipment (EMC Directive) is followed.



Warning : All the personnel that come in contact with the blower must observe following safety regulations

During Blower operation

Do not touch external surfaces of the blower and of the outlet silencer : surfaces temperature above 70 °C.

Do not open oil plugs during operation.

Do not disassemble transmission guard.

Do not approach blower without suitable clothing (avoid large clothes, neckties, bracelets or necklaces).

Do not use the blower in operating conditions different from the ones rated in the order confirmation.

Do not touch components under electric supply.

Dispose of fire-fighting equipment close to the blower

Before any staff service on the Blower

Stop the blower and auxiliary systems as described at par. 5.4



Warning : Disconnect the electric supply, lock the general switching open position with the key and conserve it during the service operation



Warning : Disconnect the inlet an outlet piping

Insulate the blower from the plant and restore the atmospheric pressure into it.



Warning : The gas contained in the plant may be hot, toxic and irritant



Warning : Wait until the blower returns at the ambient temperature (< 40°C)

During staff service on the blower

Check that all the operations indicated above have been completed.

Lift the blower and the main piping by a suitable equipment only.

During cleaning operations involving the use of sprays or cleaning agents special attention is to be paid to relevant user information to avoid the poisoning due to fumes or burns due to caustic substances.



Warning : Do not use non-original spare parts or accessories .



Note : ROBUSCHI will not be liable for any damage, breakdown, injury deriving from the use of non-original spare parts or accessories

BLOWER IDENTIFICATION

Type		
S/N		
Manufacturing year		
Conveied gas		
Absolute intake pressure		mbar
Intake temperature	T1	°C
Inlet capacity	Q1	m3/h
Discharge absolute pressure	P2	mbar
Differential pressure	P2 – P1	mbar
Discharge temperature	T2	°C
Demineralized water injection amount	Ia	l/min
Blower speed		rpm
Absorbed power	N	kW
Motor power		kW
Motor speed		rpm
Noise	SPL	dB(A)

WARRANTY CONDITIONS

The blower, if not stated otherwise by the contract, is guaranteed for 12 months of operation and in any case for a maximum of 18 months after the delivery.

The warranty apply only if the contractual and administrative norms have been observed and if the installation of the blower and its use comply with the instructions of this manual.

The damaged or defective parts due to manufacturing faults will be repaired or replaced free of charge.

The following are excluded from this warranty : all parts subject to wear (air filter, bearings etc..), transport costs and the costs of the intervention of our technicians for operational faults not due to manufacturing defects.

The warranty excludes any responsibility for direct or indirect damage to people and/or objects caused by improper use or inadequate maintenance of the blower and is limited only to manufacturing defects.

The warranty is considered void in the event of tampering or changes (even small ones) and use of non-original spare parts.

INDEX

1 BLOWER CHARACTERISTICS	23
1.1 Operating principle	23
1.2 Construction	23
1.3 Nameplate	23
2 PERFORMANCE LIMITS AND WORKING CONDITIONS	24
2.1 Operating environment and conveyed gas.....	24
2.2 Performance limits	24
2.3 Flow adjustment	24
2.4 Noise level	24
2.5 Forbidden uses.....	25
2.6 Residual risks.....	25
3 STORAGE	26
3.1 Unpacking	26
3.2 Handling	26
3.3 Preservation	26
4 INSTALLATION	27
4.1 On-site positioning of blower	27
4.2 Direction of rotation – Gas flow direction	27
4.3 Coupling	28
4.3.1 Direct coupling	28
4.3.2 Belt drive coupling	29
4.4 System piping.....	30
4.4.1 Pressure operation	30
4.4.2 Vacuum operation	30
4.4.3 Pressure /Vacuum operation	30
4.5.1 Cooling circuit for mechanical seals (only for /TM-V).....	31
4.5.2 Cooling circuit for discharge temperature	31
4.6 Electric connection	32
5 OPERATION	33
5.1 Preliminary controls.....	33
5.2 First start up	33
5.3 Operation.....	33
5.4 Stopping the blower.....	33
6 MAINTENANCE	34
6.1 Oil change	34
6.1.1 Oil type and viscosity	34
6.1.2 Suggested mineral oils	34
6.2 Replacing the shaft seal.....	35
6.3 Cleaning compression chamber.....	35
6.4 Check of the gear clearance	35
6.5 Check of the rotors clearance	35
6.6 Spare parts.....	36
6.7 Demolition of the blower.....	36
7 TROUBLESHOOTING	37
8 DISASSEMBLY AND REASSEMBLY	38
8.1 Disassembly.....	38
8.1.2 Disassembly of drive side sump	38
8.1.3 Disassembly of gear side sump.....	38
8.2 Reassembly.....	38
8.2.1 Reassembly of drive side sump.....	38
8.2.2 Reassembly of gear side sump	38
9 DRAWINGS	39
9.1 Overall dimensions.....	39
9.2 Blower sectional drawing.....	40

1 BLOWER CHARACTERISTICS

1.1 Operating principle

RBS---/TM-V RBS---/PR-V series blowers are positive displacement blowers comprising two conjugate shaped rotors 2 which rotate inside a figure 8 shaped body 1. The gas enters the blower at pressure P1 and temperature T1, it is trapped in the volume V and finally discharged from the outlet at pressure P2 and temperature T2. The capacity is proportional to the speed of rotation and is almost constant when the operating pressure varies.

P1 inlet absolute pressure
 T1 inlet temperature
 P2 outlet absolute pressure
 T2 outlet temperature

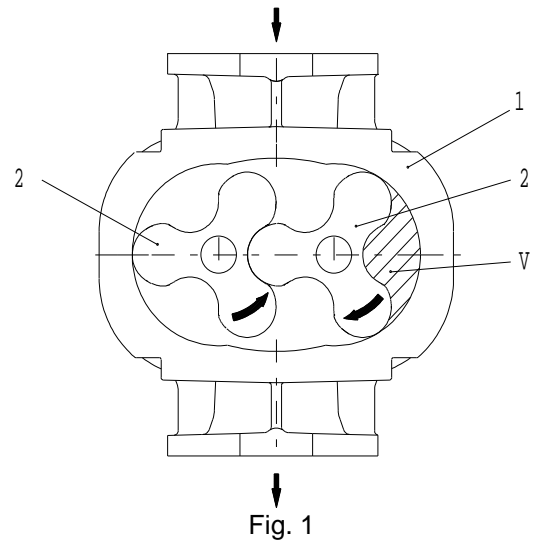

1.2 Construction

The body 1 is closed at both ends by covers 5A and 5B in which the seals 45 and bearings 31, 32 and 33 are located. The rotors 2 are synchronized by means of a gear with involute toothed wheels 11A and 11B. The shafts have labyrinth seals, gas leaks are collected into special air spaces in the covers and are discharged into the atmosphere. Two sumps 12A and 12B are mounted on the covers which act as oil tanks for the bath lubrication of the bearings and of the synchronized gear.

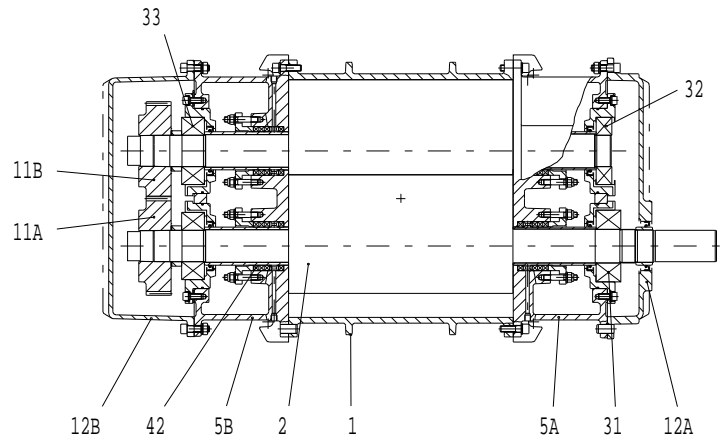

1.3 Nameplate

-Blower type

- 1) Size from 85 to 225
- 2) Version PR Soft packing
 TM Mechanical seal
 V Vertical

3) Execution 0001

- S/N Serial number
- m³/h Capacity
- kW Power
- dp mbar Differential pressure
- n RPM Rotation speed

(1)		(2)	
Type	RBS 125 / F		
S/N	0105116	exec.	0001
m ³ /h	2000	kW	55
dp	500	n	1450
mbar		RPM	
		(3)	



Note : For a detailed description of the blower materials and all its components see also the catalogue or consult our technical service.

2 PERFORMANCE LIMITS AND WORKING CONDITIONS

2.1 Operating environment and conveyed gas

The blower is suitable to operate only in dust free environment, with no-explosive or corrosive atmosphere and to convey only atmospheric Air, Nitrogen or Saturated vapor



Warning : The blower is not suitable to convey explosive, toxic or dangerous gases.



Warning : The suction of liquids damage the blower.

2.2 Performance limits

Size	RPM		P1 (mbarA)		P2-P1 (mbar)	P2/P1	T1 (°C)		T2 (°C)	T2-T1 (°C)
	MAX	MIN (1)	MAX	MIN	MAX	MAX	MAX (2)	MIN	MAX	MAX
85	3800	700	1100	200	800	2	100	-25	150	90
105	3000	550	1100	200	800	2	100	-25	150	90
115	2400	450	1100	200	1000	2	100	-25	150	110
125					800					90
135	2000	350	1100	200	1000	2	100	-25	150	110
145					800					90
165	1500	300	1100	200	1000	2	100	-25	150	110
175					800					90
205	1250	250	1100	200	1000	2	100	-25	150	110
225					700					90

To Atmospheric temperature $-20^{\circ}\text{C} < T_o < +45^{\circ}\text{C}$

Installation altitude < 1000 masl (if not differently specified on page 5)

- (1) Resonance phenomena in the plant are possible when the rotation speed is close to the minimum one
- (2) For versions with demineralized water injection T1 Max is = 110°C

2.3 Flow adjustment

Change transmission ratio

Change frequency of the motor

Use a two speed motor

Discharge excess flow and silence it



Warning : Do not use relief valve to discharge excess flow



Warning : Do not recirculate flow to blower inlet.



Warning : Do not adjust flow by throttling inlet or outlet pipe.

2.4 Noise level

Noise level of the blower is indicated at page 4 as Sound Pressure Level according to ISO 3476 at 1m distance from the blower and in free air (tolerance $\pm 2\text{dB(A)}$)



Warning : For high compression ratio and for high speed of rotation noise level of blower can be higher than 85 dB(A) .

2.5 Forbidden uses

Forbidden use	Risk	Measures
Operation in explosive atmosphere	Fire and explosion	Forbidden use
Suction of explosive, toxic and dangerous gases	Fire and explosion Environment pollution Risk of operators health	
Operation with free nozzles	Environment pollution Risk of operators health	
Suction of liquids	Blower stall and ejection of parts	Install a liquid separator on the suction nozzle of the blower
Operation with shut off valve locked	Overheating Fire Blower stall and ejection of parts	Inform the qualified personnel charged with blower
Operation with wrong direction of rotation	Ejection of dangerous substances Blower stall and ejection of parts	
Operation with speed higher than the maximum one	Blower stall and ejection of parts	Use suitable limits to the motor speed when it is supplied with frequency converter
Operation with speed lower than the minimum one		
Operation with pressure higher than the maximum one P1	Ejection of dangerous substances	Use a safety pressure switch when the blower sucks from a closed circuit
Operation with pressure lower than the minimum one P1	Blower stall and ejection of parts	
Operation with pressure higher than the maximum one P2-P1	Blower stall and ejection of parts	Set up the relief valve
Operation with pressure ratio higher than 2 P2/P1		
Operation with temperature higher than the maximum one T1	Overheating Fire Blower stall and ejection of parts	Use a safety temperature switch when the blower sucks from a closed circuit
Operation with temperature lower than the minimum one T1	Blower stall and ejection of parts	
Operation with temperature higher than the maximum one T2	Overheating Fire Blower stall and ejection of parts	Use a safety temperature switch when the blower sucks from a closed circuit
Operation with temperature higher than the maximum one T2-T1	Blower stall and ejection of parts	Use a differential temperature switch when the blower sucks from a closed circuit
Stopping the ROBOX with counter pressure	High current absorption Fire	Use a suitable stopping procedure

2.6 Residual risks

Hazard	Residual risk
UNI EN 1012-1 Compressor	
Cutting, severing, drawing in, trapping, entanglement, friction and abrasion	Do not approach the transmission guard with no suitable clothes Advice in the manual
Fluid ejection	Overcoming the operation limits (par. 2.2) can cause the risk of ejection of parts
Ejection of parts	Overcoming the operation limits (par. 2.2) can cause the risk of ejection of parts
Loss of stability	None
Electric installation	None The electric equipment is not supplied by ROBUSCHI
Electrostatic phenomena	
External influences on electrical equipment	
Thermal safety	The surface of the blower and of the discharge silencer can be higher than 70 °C Label C.7 on the surfaces Advice in the manual
Noise	The sound pressure level can be higher than 85 dB(A) Wear the noise protection devices Label C.2 on the inlet filter Advice in the manual
Suction of liquids	Forbidden use can cause the risk of suction of liquids
Gas	Forbidden use can cause the risk of suction of dangerous gases
Fire and explosion	Overcoming the operation limits (par. 2.2) can cause the risk of fire and explosion Operation with shut-off valve locked can produce the risk of fire The not correct maintenance can cause the overheating and the risk of fire
Failure of energy supply	Ejection of fluids and parts

3 STORAGE

3.1 Unpacking

Check always the correspondence between documents and materials and the presence of eventual damages due to transport.



Warning: Remove with care the packing and clearing all the dangerous elements (nails, splints, etc...)

3.2 Handling

Blower	kg
85	300
105	450
115	565
125	610
135	976
145	1099
165	1850
175	1950
205	2950
225	3350

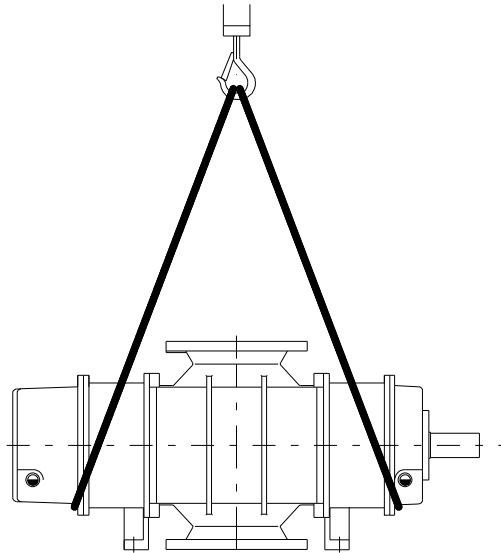

Warning : Do not use the holes in the flanges to lift the blower

3.3 Preservation

Keep the blower in a place protected against solar radiation and at following climatic conditions :

Temperature from -20°C to 40°C
 Relative humidity from 10% to 80%

If different climatic conditions are forecast contact ROBUSCHI.

Do not remove the nozzle protections and renew the preservation every 6 month or more frequently if humidity is higher than 80% using antirust oil.

Parts	Anti-rust oil	
	Type	Trade
Shiny external parts	Rustia 27 Rust Ban 397 V-Produkt 9703	AGIP ESSO SHELL
Gear and bearings	Rustia C 100 Antiruggine MZ 110 Ensis Motor Oil 20	AGIP ESSO SHELL
Compression chamber	Rustia C 100 Antiruggine MZ 45 Ensis Motor Oil	AGIP ESSO SHELL



Warning : Use anti-rust oil with fire point over 200°C



Warning : Dispose the used anti-rust oil in accordance with local regulations

4 INSTALLATION

4.1 On-site positioning of blower

The blower has to be set horizontally on a level surface and attached using screws which secure the feet.

4.2 Direction of rotation – Gas flow direction

Standard flow

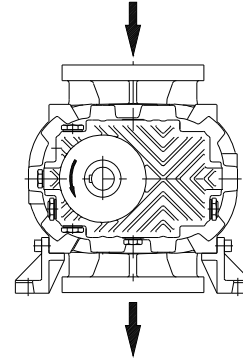

Inverted flow F.I.

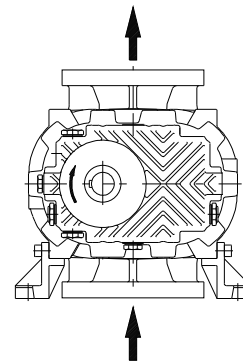

Fig. 4



Warning : Do not use the blower with a direction of rotation or a flow direction different from that one shown in Fig 4.

4.3 Coupling

4.3.1 Direct coupling

Slide the half couplings onto the shaft of the blower and of the motor using suitable tools.



Warning: Do not use a hammer to slide on the half couplings.

Secure the half couplings with security dowels which will push on the keys.

Place the blower at the distance S from the motor as indicated in the table below.

Align the shafts of the blower and of the motor by shims under the feet of the motor and/or blower.

Check the alignment by using comparators or gauges with scales as shown in Fig. 5

Coupling diameter	Distance S (mm)	Axial deviation Ka (mm)	Standard deviation	
			Radial Kr (mm)	Angular Kw (mm)
80	3	1	0.13	0.13
100	3	1	0.15	0.15
130	3	1	0.18	0.18
150	3	1	0.21	0.21
160	4	2	0.27	0.27
180	4	2	0.30	0.30
200	4	2	0.34	0.34
225	4	2	0.38	0.38
250	5.5	2.5	0.42	0.42
280	5.5	2.5	0.47	0.47
315	5.5	2.5	0.52	0.52
350	5.5	2.5	0.58	0.58

Alignment check

$$S_{max} < S + K_a$$

$$S_{min} < S - K_a$$

$$K_v = 1.5 \frac{\text{rpm}}{3000}$$

$$\Delta r = K_r \times K_v$$

$$D_w < S_{max} - S_{min}$$

$$D_w < K_w \times K_r$$

$$\Delta r + D_w < K_w \times K_v$$

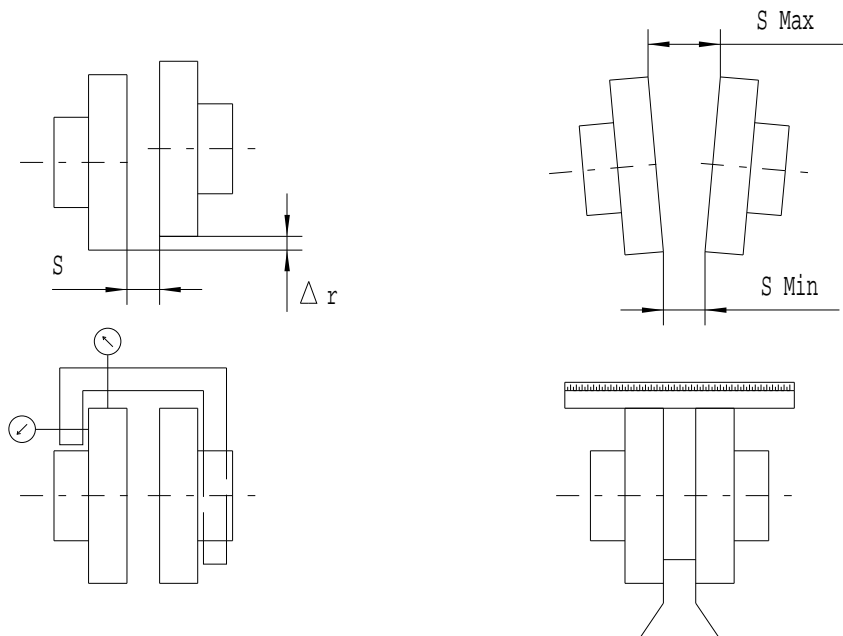

Fig. 5



Warning : Alignment errors cause premature wearing of the bearings and flexible couplings.

4.3.2 Belt drive coupling

Utilize pulleys with minimum diameter equal or major than the value indicated in the table below.



Warning : Do not use a hammer to mount the pulleys.

Use suitable equipment to mount the pulleys onto the blower and motor shafts.

Minimum allowed blower pulley pitch diameter

Size	Differential pressure (mbar)								
	200	300	400	500	600	700	800	900	1000
85	100	106	112	118	125	132	140	150	160
105	112	118	125	132	140	150	160	180	200
115	106	112	118	125	132	140	150	160	180
125	118	125	132	140	150	160	180		
135	112	118	125	132	140	150	160	180	200
145	125	132	140	150	160	180	200		
165	150	160	180	200	225	250	280	300	325
175	180	200	225	250	280	300	325		
205	200	225	250	280	300	325	350	400	450
225	280	300	325	350	400	450			

Mount the drive belts

Produce belt tension by using the motor thrust screws in accordance with the values shown in the table

Belt profile	Force F [daN]	Diameter D of smaller pulley [mm]	Constant E
SPZ XPZ	2.5	95 – 125 > 132	1.45 1.30
SPA XPA	5.0	100 – 140 150 – 200 > 224	2.30 2.10 2.00
SPB XPB	7.5	160 – 224 236 – 355 > 375	1.55 1.20 1.10
SPC XPC	12.5	250 – 355 375 - 560	1.80 1.60

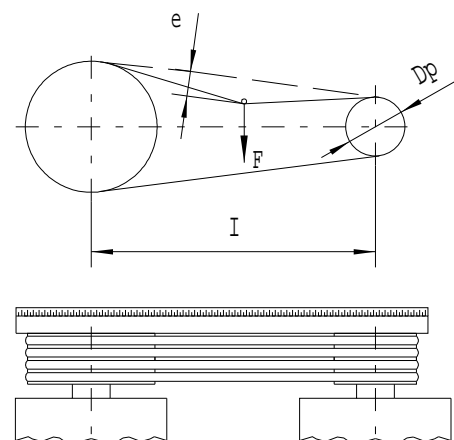

$$e = I \times E / 100$$

Fig. 6

$e = I \times E / 100$, where I is expressed in mm



Warning : Excessive belt tension could damage the blower and the motor

During this phase check the alignment of the pulley by using a scale as per Fig. 6
Secure the feet of the motor

4.4 System piping

The diameters of the system piping must be chosen in order to obtain an average gas speed from 15 to 30 m/s and must never be smaller than the diameters of the blower openings, if the diameters are different, use a taper connector.

The system piping should be properly aligned and supported to prevent stress on the blower openings.

Provide flexible joints and support the pipes near the nozzles.

Isolate the pipes to avoid heating the environment as well as a precaution to accidental contact

The pipes must be thoroughly cleaned before connection, in case of vacuum operation install a dirt filter for the first 100 working hours and provide a vacuumeter to check the dirt filter.

The gaskets must not interfere with the gas system.



Warning: The surface of discharge pipes can exceed 70°C



Warning : Remove the protective covers from the blower openings just before connection.

The recommended accessories are the following

4.4.1 Pressure operation

Pos.	Description
F	Filter
SPF	Inlet silencer
SM	Outlet silencer
RVP	Relief valve
WR	Check valve
VRA	Starting valve

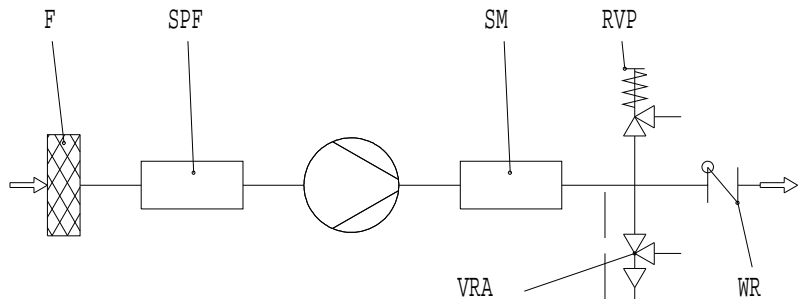

4.4.2 Vacuum operation

Pos.	Description
WR	Check valve
RVV	Safety valve
SPF	Inlet silencer
SM	Outlet silencer

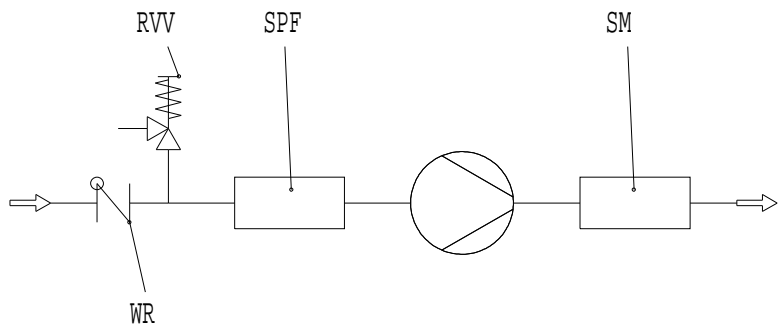

4.4.3 Vacuum/Pressure operation

Pos.	Description
WR	Check valve
RVV	Relief valve
SPF	Inlet silencer
SM	Outlet silencer
RVP	Safety valve

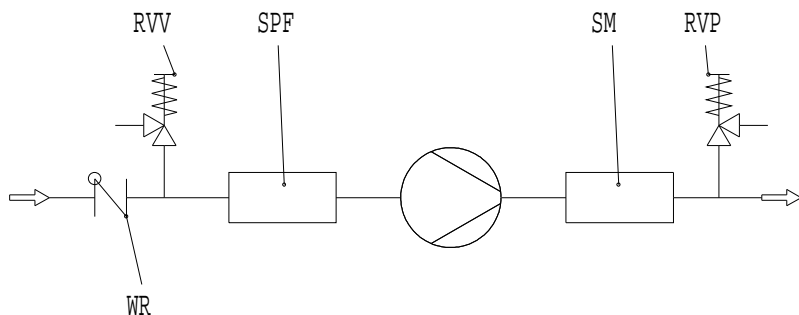

4.5.1 Cooling circuit for mechanical seals (only for /TM-V)

Pos	Description
Rp	Pressure reducer
Vi	Shut-off valve
M	Pressure gauge
Vr	Adjusting valve
Fm	Flowmeter

Cooling water flow rate at 20 °C	
Size	m3/h
85	1,0
105	1,1
115 – 126	1,2
135 – 145	1,2
165 – 175	1,4
205 – 225	1,4

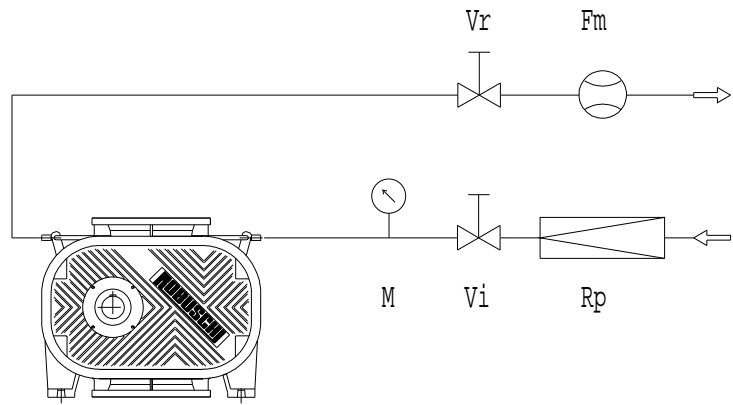

Fig. 7

Warning : To avoid the danger of winter freezing use anti-freeze (any type used for car radiators)

The pressure of cooling liquid must be 0,5 bar higher than the outlet pressure of the blower in order to avoid the opening of the internal seal (rotor side).

Warning : The pressure of cooling liquid do not overcomes 4 barg.

4.5.2 Cooling circuit for discharge temperature

Differential temperature and T2 have to comply performance limits indicated in paragraph 2.2.

If required, depending on suction temperature of the application in order to remain within the temperature performance limits it is possible to inject demineralized water (with temperature 15°C ÷ 80°C) in the inlet of the blower as indicated in the following scheme:

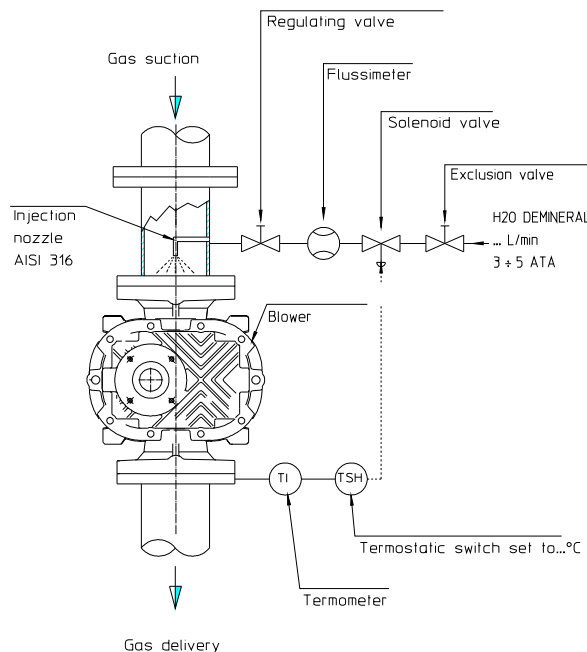

Thermometer TI have to regulate the water amount by the solenoid valve in order to maintain the discharge temperature T2 to the value indicated at page 4. Thermostat TSH set at 145°C have to intervene to stop the blower in case of cooling circuit malfunctioning.

4.6 Electric connection

Electric connections must be set up by authorized specialists in compliance with regulations applying to the place of installation and in accordance with the requirements of the local body supplying electrical energy.



Note: Robuschi refuses all responsibility for electric connection not complying with the law in force.

Check on the motor plate : Voltage, Absorbed current, Frequency, number of phases.

Check the wiring diagram in the terminal board of the motor , if the diagram has not been supplied request it from the motor manufacturer.

Use suitable electric cables depending on the nominal current of the electric motor.

Keep the electric cables away from heat sources and/or pointed edges

Protect the motor by means of automatic switch set at the rated current shown on the motor plate

Install a local control panel with an emergency push button between supply line and the motor of the blower



Warning : The emergency push-button must be easily reached by the operator

For the safety of personnel the system must be protected by a suitable grounding device



Warning : Blower service must be carried out after disconnecting the electrical supply.

5 OPERATION

5.1 Preliminary controls

If the blower has been in storage for more than 6 months, check its state of preservation.
 Check the alignment of the transmission and eventually the belt tension .
 Check that the blower rotate freely by hand.
 Check that the safety protection devices have been correctly installed and secured.
 Check that the pipes have been internally cleaned and if eventually obstructions have been removed.
 Check that all connections between pipes and blower are tightened and sealed.
 Fill the blower with oil as described in paragraph 6.1

5.2 First start up



Warning : The personnel must wear the noise protection devices.

Open the shut-off valve.
 Check that the safety valve has been set at the operating value.
 Check the rotation direction using a short current pulse.



Warning : Do not rotate the blower in the wrong direction for more than a few revolution.

Open the valve of the cooling circuit (only /TM-V version)



Attention : In steam applications verify that the temperature difference between steam and blower main body is lower than 20°C.



Nota : In steam applications in order to heat the blower it's possible to inject steam with machine not in operation until the proper blower body temperature is reached

Start the blower.

Increase the operating pressure gradually until the rated value is reached.
 During the first 8 hours of operation check that there are no oil leakage, no cooling liquid leakage (only /TM-V) and strange noises or vibrations, if such problems are found stop the blower immediately and contact our PV service.

5.3 Operation

Start the blower and check what enlisted in the table below.

CHECK	PARAMETER	FREQUENCY				NOTE
		h	G	S	M	
VISUAL	Pressure		1			Blower in operation
	Temperature		1			
	Absorbed power		1			
	Cooling liquid flow		1			
	Noise		1			
SEALS	Cooling circuit		1			
LUBRIFICATION	Oil level	500				Blower out of operation
	Oil Leakage			1		
	Viscosity	500				
	Oil change	4000			6	
FILTER	Vacuum		1			< 35 mbar
	Clogging				2	
TRANSMISSION	Wear	2000				Blower out of operation
	Belt tension	2000				
	Belt change	15000			24	

h operation hours
 application
 S weeks

G days
 M months

Note : in case of double indication follow the most limiting one for the

5.4 Stopping the blower

Remove, if possible, the differential pressure.



Note : The blower can also be stopped in the presence of the counter-pressure, but, because the high current absorption of the motor, problems with the electric circuit may occur.

Stop electric supply and close the cooling water circuit (only TM-V version)



Warning : Check that the deceleration of the blower is even and without vibrations.

6 MAINTENANCE

Stop the blower and auxiliary system as indicated in the paragraph 5.4



Warning : Disconnect the electric supply, lock the general switching in open position with the key and conserve it during the service operation



Insulate the blower from the plant and restore the atmospheric pressure into it



Warning : The gas contained in the plant may be hot, toxic and irritant



Warning : Wait until the blower returns at ambient temperature (<40°C)

6.1 Oil change

The first oil change is performed after 500 working hours, further changes as per table in the paragraph 5.3

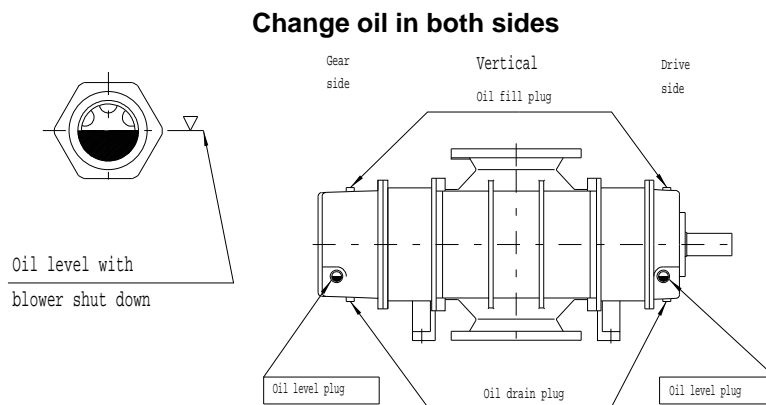

Fig. 9

Size	Oil quantity (lt)		
	Gear side	Drive side	Total
85	2,00	0,90	2,90
105	3,50	1,60	5,10
115-125	4,80	2,80	7,60
135-145	10,50	6,00	16,50
165-175	18,00	10,00	28,00
205-225	30,00	16,00	46,00



Warning : Dispose the used oil in accordance with local regulations

6.1.1 Oil type and viscosity

Mineral oil for general use, mineral oil for hydrostatic and hydrodynamic circuits, mineral oil for internal combustion engines or polialfaolefine base synthetic oil.



Warning : Do not use mineral oil with EP additives or silicon or diester base synthetic oils.

Oil type	Viscosity	Use			
		Tambient	T2	Toil	Note
Mineral	100	< 0	< 90	< 50	Check the poor point
Mineral	150	< 35	< 110	< 80	
Mineral	220	< 50	< 130	< 110	Installation in soundproof enclosure
Synthetic	220	> 50	> 130	> 110	

6.1.2 Recommended mineral oils

Make	Type	ISO VG - 150	Poor point	ISO VG - 220	Poor point
AGIP	RADULA	150	-20	220	-18
BP	ENERGOL	CS 150	-12	CS 220	-12
ESSO	NUTO	150	-18	220	-18
MOBIL	D.T.E.	EXTRAHEAVY	-9	BB	-7
SHELL	TELLUS	C 150	-18	C 220	-15

6.2 Replacing the shaft seal

For the identification of parts see the sectional drawing at page 38

Disassemble the drive

Empty the lubricating oil out of the sump 12A



Warning : Dispose the used oil in accordance with local regulations

Disassemble the sump 12A

Clean the housing of any residues and/or deposits.

Replace the seal ring pos. 43

Reassemble the sump 12A

Refill the sump 12A with new lubricating oil as per paragraph 6.1.2

Couple the motor as shown in paragraph 4.4.1 o 4.4.2.

6.3 Cleaning of compression chamber

Clean the internal surface of the chamber and the surface of the rotors from any deposits and rust by using solvents and a scraper



Warning : Keep to prescribed safety rules when using solvents and wear protection glasses and safety gloves



Note : Do not damage the internal surface of the chamber and the surface of the rotors surface when using the scraper.

6.4 Check of the gear clearance

For the identification of parts see the sectional drawing 278809-0071 at page 37

Empty the lubricating oil out of the sump 12B



Warning : Dispose the used oil in accordance with local regulations

Disassemble the gear sump 12B

Measure the clearance between the gear teeth according to the attached table 264468 . In order to do this secure one of the gears and rotate the other until there is no contact.

Reassemble the sump 12B

Refill the sump 12B with new lubricating oil as shown in paragraph 6.1.2

Send the table 264468 filled out with measured clearances to ROBUSCHI. (or any authorized distributor) for their review.

6.5 Check of the rotors clearance

Disassemble the inlet piping

Insert gauges into the inlet opening to measure the clearance of the rotors in various positions, turning the drive shaft by hand according to the attached table 264468.



Warning : During this operation pay attention to rotors which can cause the squeezing of the finger and hands.

Reassemble the inlet piping together with the silencer if present

Send the table filled out with measured clearance to ROBUSCHI. (or any authorized distributor) for their review.

6.6 Spare parts

In the table below are indicated the recommended spare parts for normal use of the blower according to the forecast timing.

For the spare parts of blower spare parts refer to sectional drawing at page 38.

Pos.	Description	Operation				
		Start-up	2 year	5 year	10 year	
	11 A - B	Gears (couple)	-	-	-	1
	16 A - B	Lubricating disc (couple)	-	-	-	1
	26	Nut (couple)	-	-	1	2
(1)	27 A	Nut	-	-	1	2
	27 B	Nut	-	-	1	2
	31 - 32 - 33	Bearing (set)	-	-	1	2
	37	Shaft sleeve	1	2	4	8
(2)	3842A	Shaft sleeve (set)	-	1	2	4
(1)	3842A, 3842B	Shaft sleeve (set)	-	1	2	4
	4200	Soft gland ring (/PR-V) (set) Or TM seal		1	2	4
	43	Seal ring	1	2	4	8
	44	Seal ring (set)	1	2	4	8
	50	Gaskets (set)	1	2	4	8
	51	Gaskets (set)	1	2	4	8
(1)	52A 52B 52C	Bearing housing (set)		1	2	4
	76 - 77	Oil draining plugs (set)	1	2	4	8
	78	Oil level plugs (set)	1	2	4	8

(1) Only for unit from RBS 115 to RBS 225

(2) Only for unit from RBS 85 to RBS 105

In case of order please quoting always Type, serial number and year of construction of the blower (these elements are indicated in front page of this manual) and relevant position of spare part indicated in the table



Warning : Do not use non-original spare parts or accessories .



Note : ROBUSCHI will not be liable for any damage, breakdown, injury deriving from the use of non-original spare parts or accessories

6.7 Demolition of the blower

In case of demolition of the blower verify the eventual presence of explosive, toxic or dangerous substances and dispose them in accordance with local regulations.



Warning : Dispose the used oil in accordance with local regulations.





Warning : Dispose the filter element in accordance with local regulations.

Demolish the blower in such a way to make impossible to use again ROBOX as complete unit, or to use again one or several parts of the blower.



Note : Destroy the name-plate of the blower and any other document

7 TROUBLESHOOTING

Operating problems	List of causes
The motor does not start up and there is no noise	1-3-4
The motor does not start up, but humming noise is heard	2-3-4-5-6-7
Automatic cut off just after start up	3-4-5-6-7
Inlet pressure different from the rated value	13-16
Outlet pressure different from the rated value  WARNING : STOP THE BLOWER IMMEDIATELY	14-16
Outlet temperature different from the rated value  WARNING : STOP THE BLOWER IMMEDIATELY	8-13-14-16-17
High absorbed power	3-5-6-7-9-13-14-16-19
Oil and/or liquid leakage	10-11-12-15-19
High oil temperature	13-14-16-17-18-19-21
Unusual noises and/or vibrations  WARNING : STOP THE BLOWER IMMEDIATELY	5-6-7-8-9-13-14-17-22

	Cause	Solution	Rif.
1	At least 2 of electric connections have been cut off	Check the fuses, terminal boards and connection cables and if required replace them.	4.6
2	1 electric connection has been cut off.	See point 1.	4.6
3	Incorrect electric connection	Check electric system	4.6
4	Faulty motor	Check the electric motor	4.6
5	Rotors making contact	Stop the blower immediately and check the internal clearances of the rotors and of the gear	6.4 6.5
6	Scale deposits in the compression chamber	Clean the compression chamber and the rotors, balance the rotors if necessary	6.3
7	Intake of foreign particles	Remove the foreign particles, clean the compression chamber and check the clearances	6.3 6.4 6.5
8	Rotors are worn	Check the internal clearances	6.5
9	Bearing are worn	Replace the bearings	(1)
10	Gaskets are worn	Replace the gaskets	(1)
11	Drive shaft seal is worn	Replace the seal	6.2
12	Oil level plugs are broken	Replace the oil levels	(1)
13	Inlet piping is clogged	Check piping and remove obstruction	4.4.1
14	Outlet piping is clogged	Check piping and remove obstruction	4.4.2
15	Cooling circuit or mechanical seals damaged (only /TM-V)	Restore the circuit Replace the seals	4.5
16	Speed of rotation different from rated value	Reset the rated value	(1)
17	Inlet temperature different from rated value	Reset the rated value	(1)
18	Cooling liquid capacity different from rated value (only /TM-V)	Reset the rated value	4.5
19	Oil level too high	Reset correct oil level	6.1
20	Oil too viscous	Use less viscous oil	6.1.1
21	Oil produces foam	Change the type of oil	6.1.1
22	Transmission not aligned	Check the alignment	4.3

(1) Check the plant

8 DISASSEMBLY AND REASSEMBLY

Disassembly the blower within the guarantee period results in the cancellation of the guarantee.
Disassembly, repair work and reassembling of the blower must be carried out only by **qualified personnel** and with the aid of suitable equipment and relevant manual.
This manual contains only the instructions for preventative maintenance.
For any references to components see attached sections



Note : Guarantee does not cover damages caused by operations carried out incorrectly during disassembly and/or reassembling of the blower.

8.1 Disassembly



Warning : Before starting disassembly stop the blower by following the procedure described at paragraph 6.

Disassemble the drive components (pulleys or coupling) following the manufacturer's instructions if there are locking devices or by means of an extractor if attached directly onto the shaft.



Warning : Do not hammer the shaft coupling or pulley.

Empty the cooling circuit and disconnect the relevant piping.
Drain the lubricating oil from the sumps 12A e 12B



Warning : Dispose the used oil in accordance with local regulations

8.1.2 Disassembly of drive side sump

Remove the key 30.

Lock the cover 5A to the casing with at least 4 clamps.

Loose the fixing screws and extract the sump 12A together with seal ring pos. 43

8.1.3 Disassembly of gear side sump

Lock the cover 5B to the casing with at least 4 clamps.

Loose the fixing screws and extract the sump 12B .

8.2 Reassembling

Before reassembling, thoroughly clean all components and lubricate with oil those components which have to slide over each other.

8.2.1 Reassembling of drive side sump.

Mount the seal ring 43 onto sump 12A using special equipment in order to avoid damaging the lip of the seal.

Lubricate the lip of the seal and sliding housing on the shaft with grease.

Mount the sump 12A on the cover 5A with a new gasket 50 in between.



Warning : Do not damage the lip of the ring 43.

Secure the sump 12A with the relevant screws

8.2.2 Reassembling of gear side sump

Mount the sump 12B onto cover 5B with a new gasket 50 in between.

Secure the sump 12B with the relevant screws



PD Blower & Vacuum Pump Service & Repair Facility

120 – 10293 276 ST, Acheson, Alberta, Canada T7X 6A5

T: 780.962.1827 F: 780.962.1830 E: sales@fraserwoods.ca

www.heliopower.com.eg